

**Housing Sections
60 Amp**

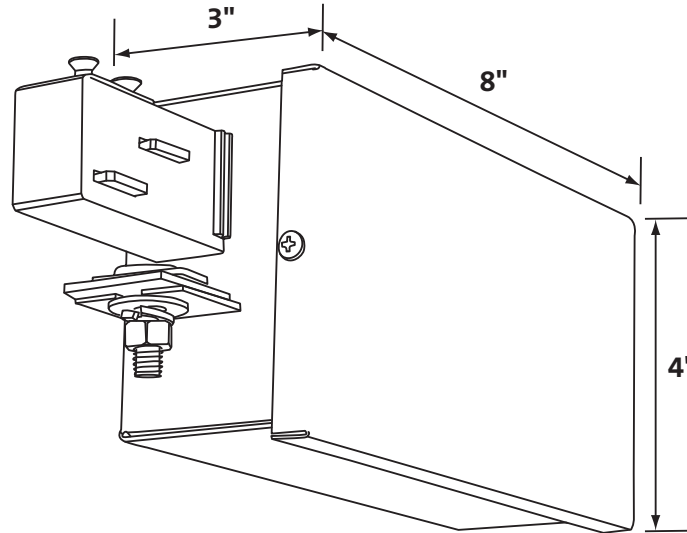

Built-in Connector - CEPF Series

Specifications/Features

Housing Sections

End Feed with Connector - Consists of steel junction box with removable side, a terminal block for field connections and an in-line connector already terminated to one side of terminal block. Unit is inserted into the busway and held in position via bolted connection to busway.

Warranty

This busway system is covered by Con-Tech's one year full replacement guarantee after installation.

Listing

cULus listed. Suitable for dry locations.

Ordering Information

Example Order: -

Busway

CEPF60 - With Built-in Connector

System Poles

2
4