

# WS012

## Spheris

### Quarter Sphere Plastic Incandescent Wall Sconce

Catalog No. \_\_\_\_\_

Type \_\_\_\_\_

Project \_\_\_\_\_

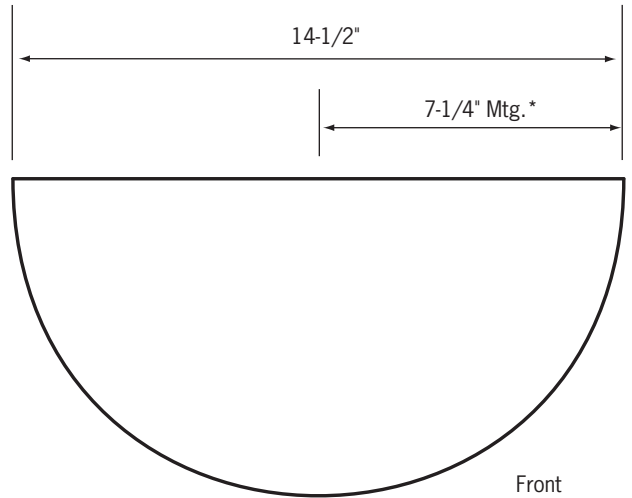
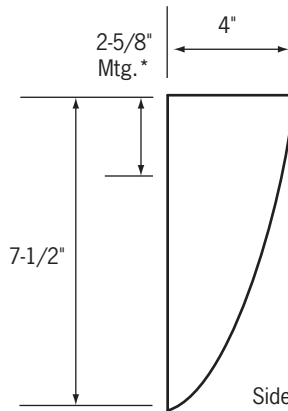

\*Mounting Location Shown For Center Of Junction Box.

### Specifications/Features

#### Fixture

Translucent diffuser provides a soft luminous glow and directs light upward for low glare applications.

This design blends the perfect size and illumination for hallways, reception areas, or individual rooms and offices.

ADA compliant for use throughout your building space.

Steel back pan with high reflectance white paint for greater light output.

#### Lamp/Electrical

(2) 13W (G24Q-1 Base), 18W (G24Q-2 Base) or 26W (G24Q-3) Base, 120V Quad Lamps.

Electronic ballast options for (2) 13W, 18W or 26W lamps with multi-volt input voltage of 120V to 277V.

#### Mounting

Hardware included for mounting of fixture to octagonal or rectangular switch junction box.

#### Warranty

This fixture is covered by Con-Tech's full one (1) year replacement guarantee after date of purchase.

#### Listing

cULus listed. Suitable for dry locations.

### Ordering Information

Example Order:

Fixture

**WS012**

Lamp/Ballast

**213E12** - (2) 13W Quad Lamps, G24Q-1 Base, Single Volt Electronic Ballast, 120V

**218E12** - (2) 18W Quad Lamps, G24Q-2 Base, Single Volt Electronic Ballast, 120V

**226E12** - (2) 26W Quad Lamps, G24Q-3 Base, Single Volt Electronic Ballast, 120V

Optional Decorative Bands

**AB** - Single Antique Bronze Band

**NI** - Single Nickel Band

**PB** - Single Polished Brass Band

**PC** - Single Chrome Band

